

tGard Bodies

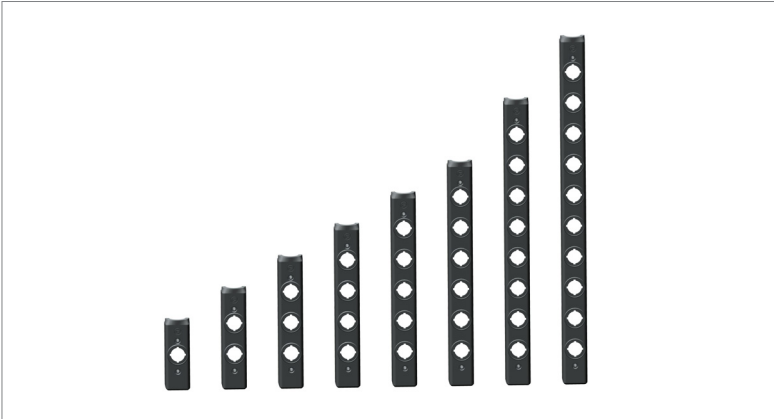

**Bodies**

tGard bodies are available as the following configurations.

- 1 way
- 2 way
- 3 way
- 4 way
- 5 way
- 6 way
- 8 way
- 10 way

**Technical Specification**



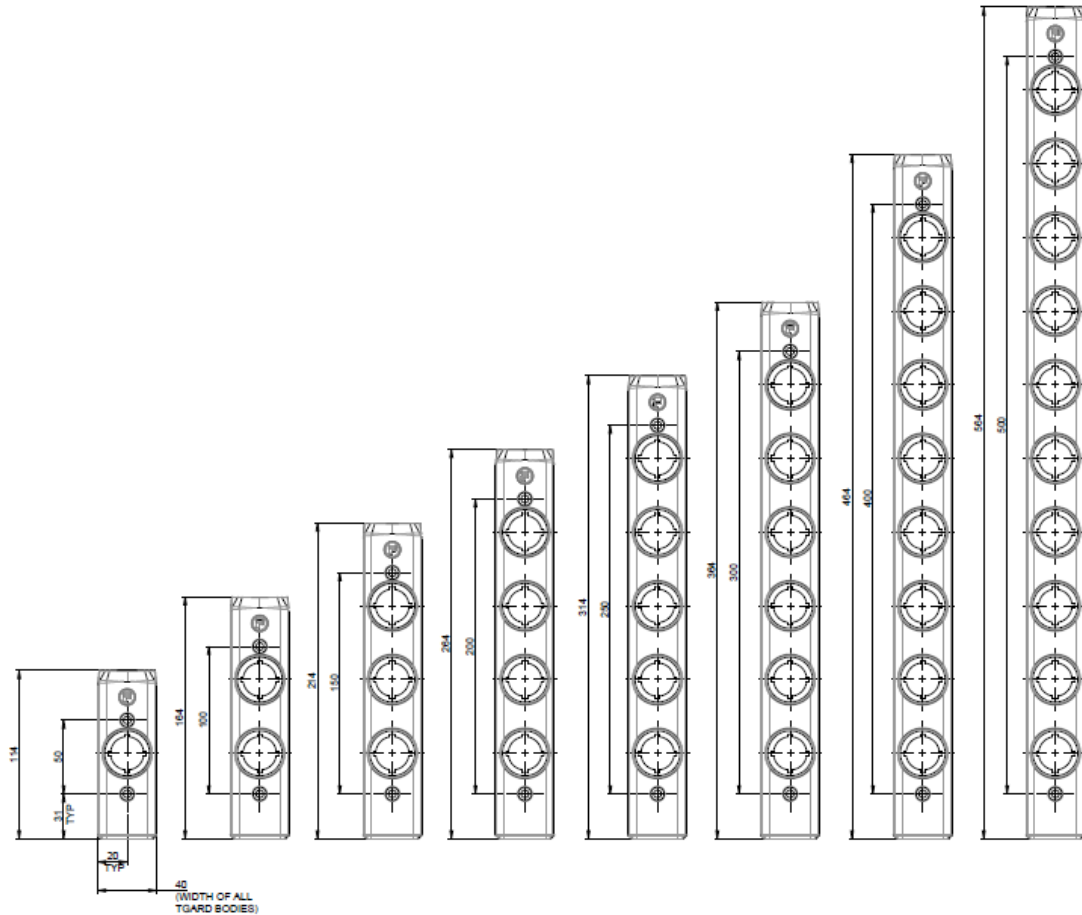

Housing Materials	Painted die cast aluminium
Colour	Dark Grey
Ambient Temperature	-5°C to +40°C (23°F to 104°F)

*\*IP protection is to the tGard stack that this module attaches to, when correctly fitted according to installation and maintenance instructions.*

Dimensional Drawing - Bodies

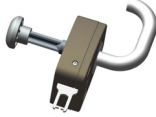

Actuators

TAF	TAH	TAS	<p><b>TAF - Fixed Actuator</b></p> <ul style="list-style-type: none"> <li>Fixed Actuator suitable for mounting on either sliding or hinged doors.</li> </ul> <p><b>TAH / TAS - Handle Actuators</b></p> <ul style="list-style-type: none"> <li>Handle actuators suitable for bracketless mounting to either hinged (TAH) or sliding (TAS) doors.</li> <li>4mm misalignment feature.</li> <li>TAH actuator can be converted to a TAS actuator on site, and vice versa.</li> </ul> <p><b>TEH / TEN - Handle Actuators</b></p> <ul style="list-style-type: none"> <li>Intuitive handle actuator giving latching feature on hinged doors.</li> <li>4mm misalignment feature</li> <li>Lock out tagout.</li> <li>Handing can be changed on site.</li> </ul> <p>Note: The internal knob on TEH handle does not override the solenoid or lock. A TRX/Z (internal release element) must be used to deliver that functionality.</p> <p>To be used in combination with a THM head module.</p>
			
			
	TEN	TEH	

Safety Data	
Standards	EN13849-1:2008 EN13849-2:2012 EN62061:2005 EN14119:2013
Certifications	CE marked for all applicable directives
Category	Cat. 4, PL <sub>e</sub> (EN/ISO 13849-1) and SIL3 (EN/IEC 62061)
Functional Safety Data	B10d 5,000,000

Technical Specification	
Housing Materials	Painted die cast aluminium
Colour	Dark Grey
Ambient Temperature	-5°C to +40°C (23°F to 104°F)
Actuator Material	Stainless Steel
Retention Force	2500N

Head Module Part Number Options	
Part Number	Description
TAF	Fixed Actuator
TAH	Hinged Door Actuator
TAS	Sliding Door Actuator
TEH	Handle Actuator
TEN	Handle Actuator (no internal knob)

Dimensional Drawing - TAF

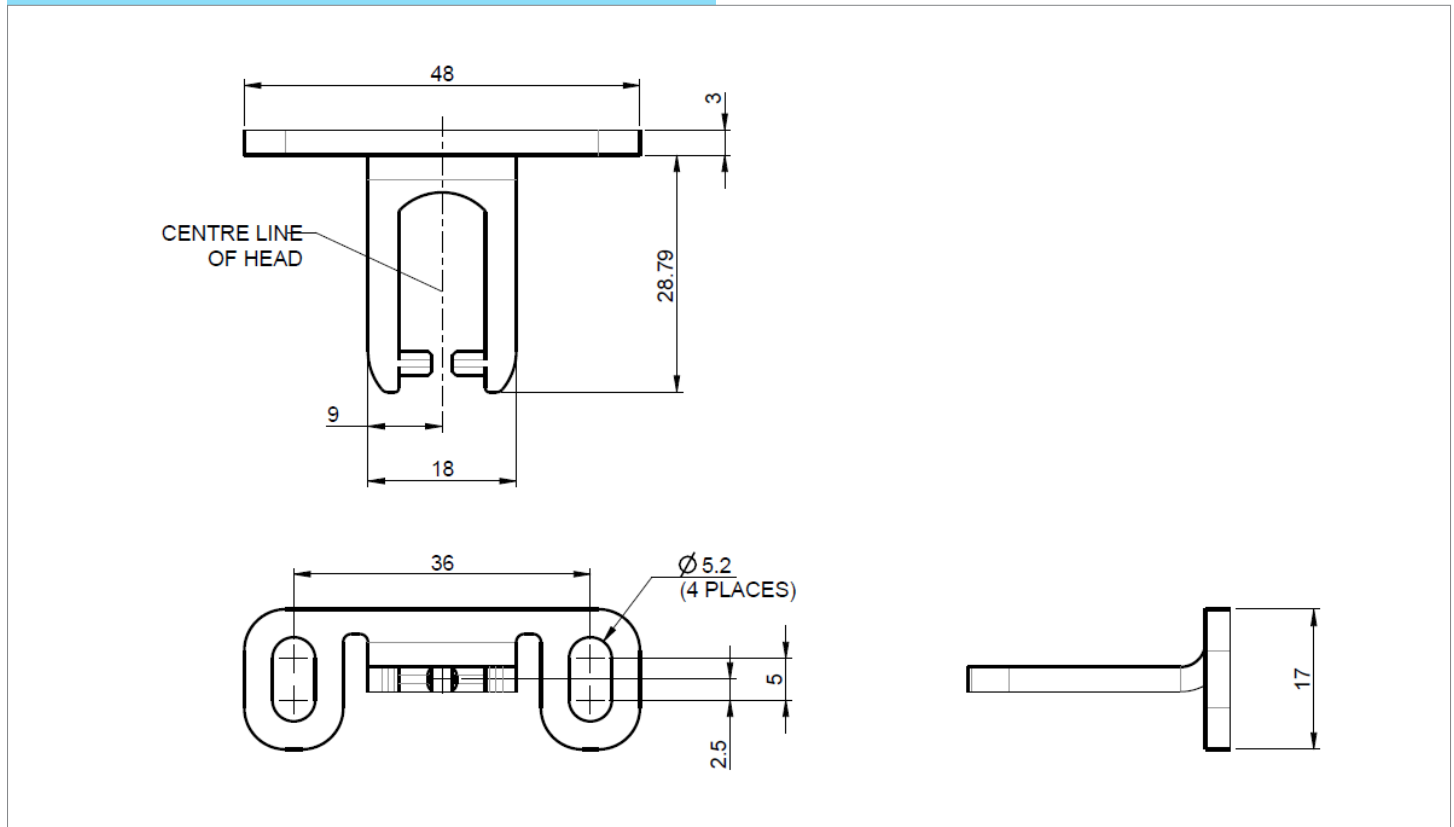

Actuators

Dimensional Drawing - TAH

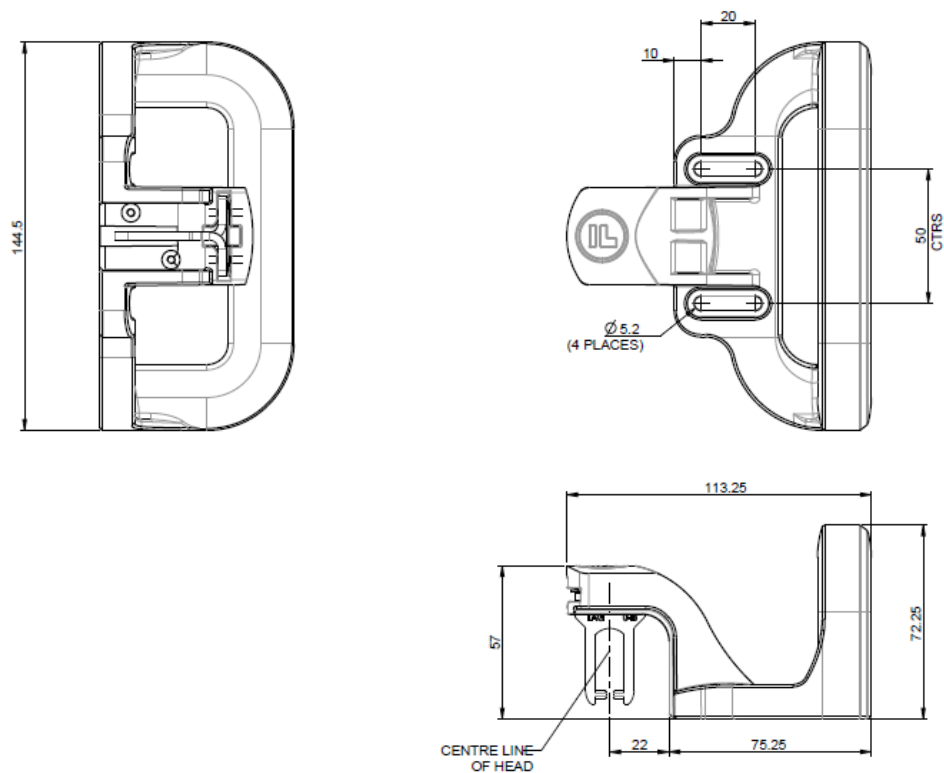

Dimensional Drawing - TAS

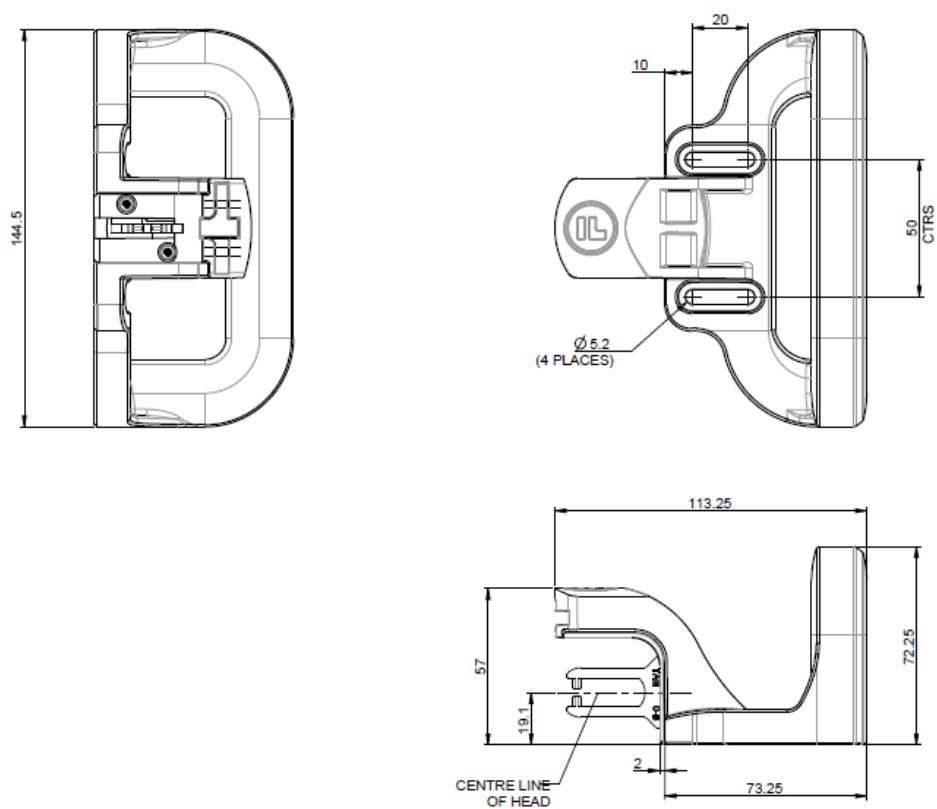

Actuators

Dimensional Drawing - TEH

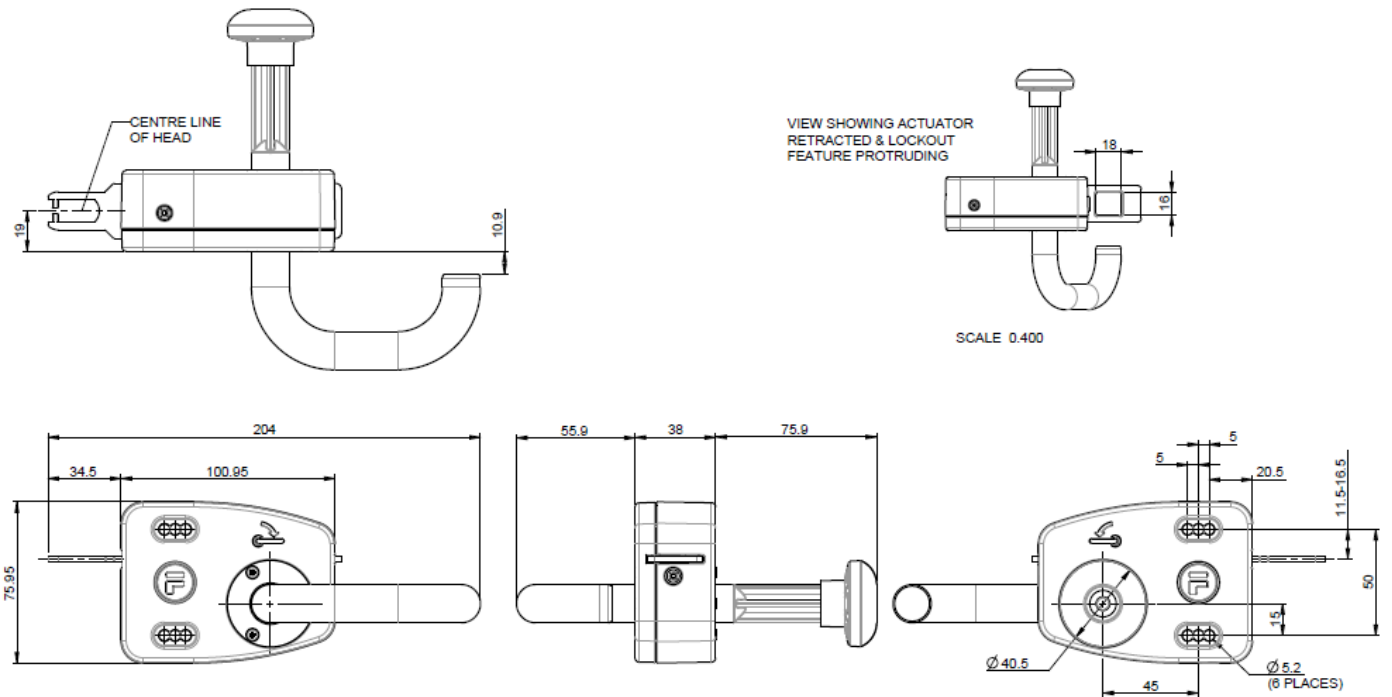

Dimensional Drawing - TEN

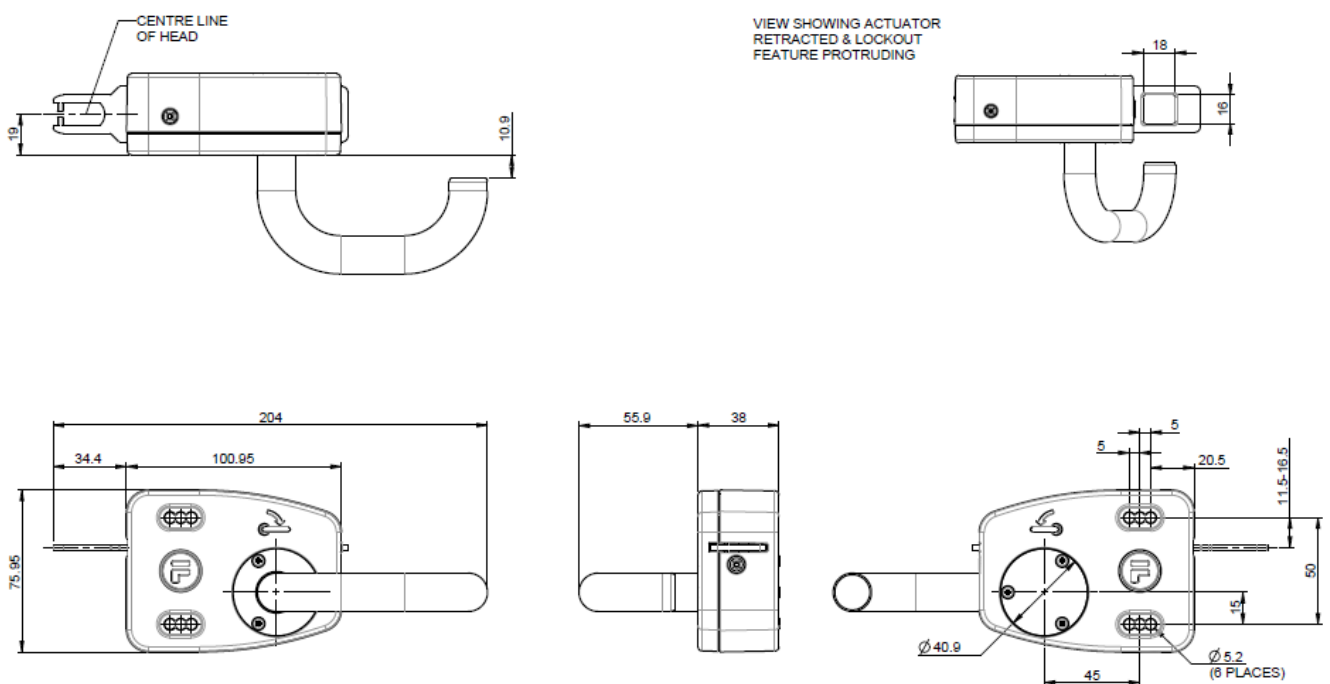

Head Elements

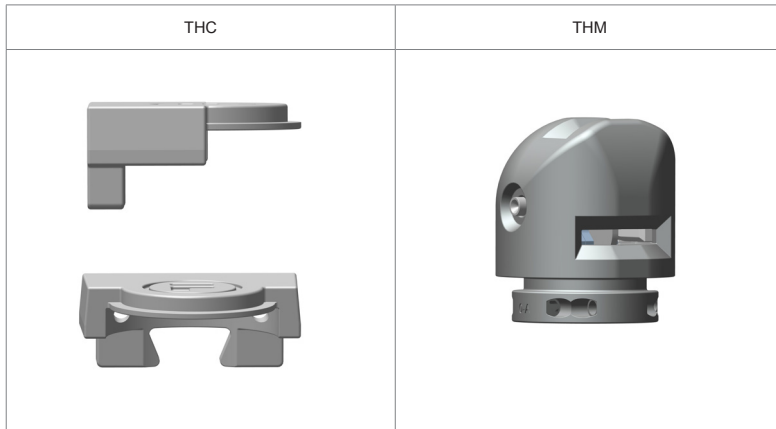

**Cap Element - THC**

Used to terminate all non door lock or gate switch configurations. Used in mechanical exchange box, machine control or key switch configurations.

**Actuator Head Element - THM**

Ideally suited for authorised access only, or linked access to other machinery.

- 5 orientations (left, right, front, back and top).
- Can be used to lock door when used with keys or solenoid or just as driver for safety switches.

Safety Data	
Standards	EN13849-1:2008 EN13849-2:2012 EN62061:2005 EN14119:2013
Certifications	CE marked for all applicable directives
Category	Cat. 4, PLe (EN/ISO 13849-1) and SIL3 (EN/IEC 62061)
Functional Safety Data	B10d 5,000,000

Technical Specification	
Housing Materials	Painted die cast aluminium
Colour	Dark Grey
Ingress Protection	IP65*
Operating Force	5N to 10N
Retention Force Locked	2500N
Mechanical Life	1,000,000 Operations
Maximum Frequency of Ops	1 per second
Ambient Temperature	-5°C to +40°C (23°F to 104°F)
Min hinged door radius	150mm (using TAH actuator handle)

\*IP protection is to the tGard stack that this module attaches to, when correctly fitted according to installation and maintenance instructions.

Head Module Part Number Options	
Part Number	Description
THC	Cap only
THM	Head only
Head + Actuator Combined Part Number Options	
Part Numbers	Description
THM + TAF = THF	Head module including fixed actuator
THM + TAS = THS	Head module including sliding actuator
THM + TAH = THH	Head module including hinged actuator
THM + TEH = THE	Head module including handle actuator
THM + TEN = THN	Head module including handle actuator (no internal knob)

Dimensional Drawing - THC

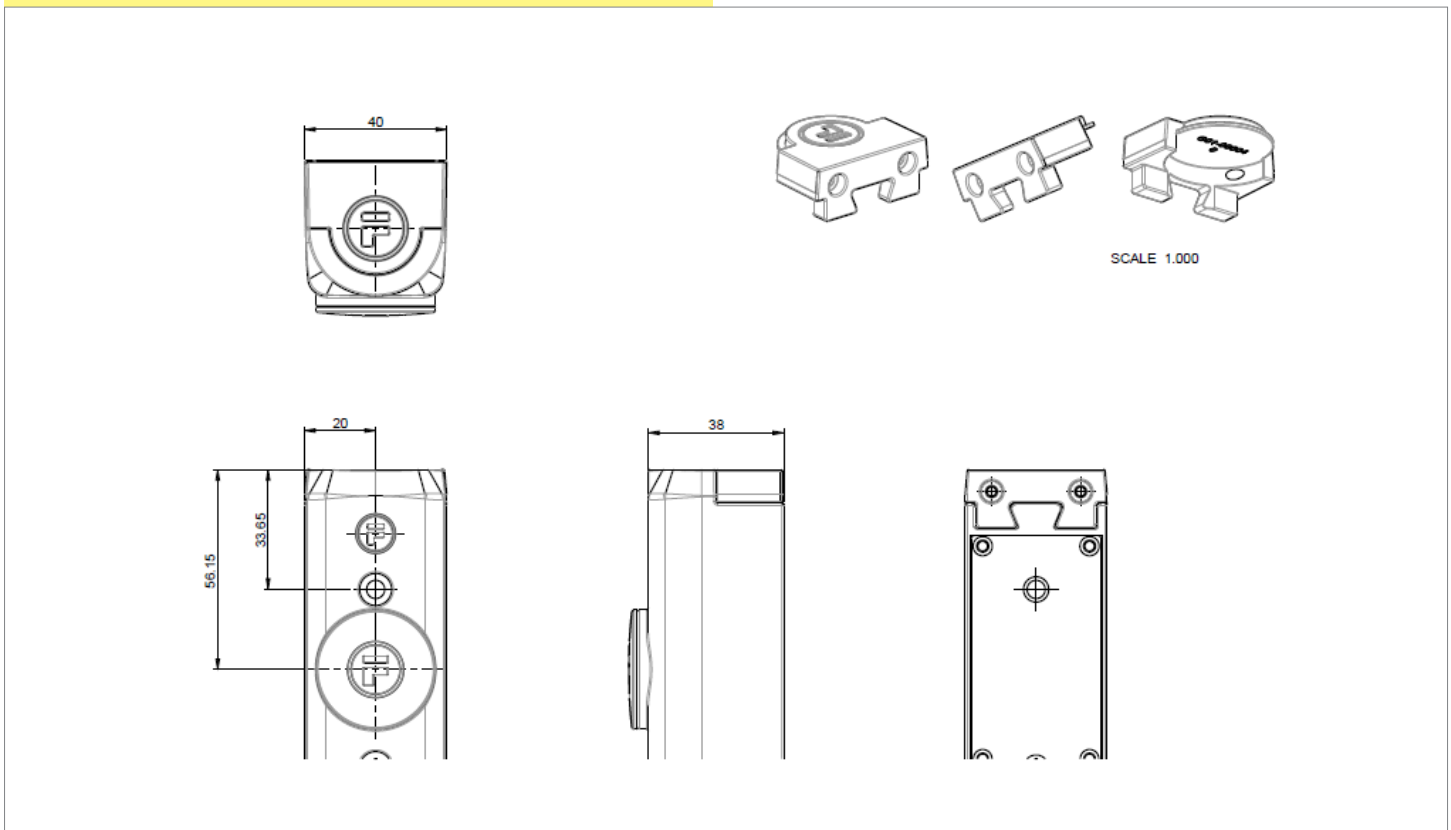

Head Modules

Dimensional Drawing - THM

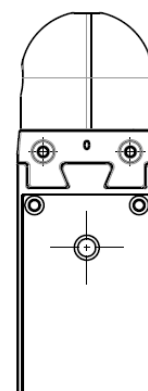
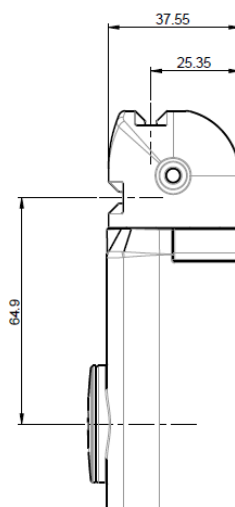
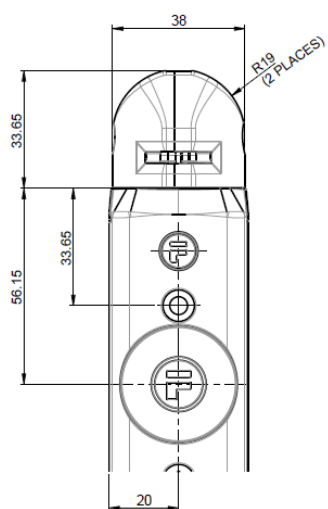
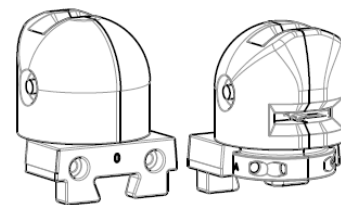
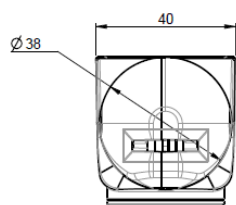

Internal Release Element

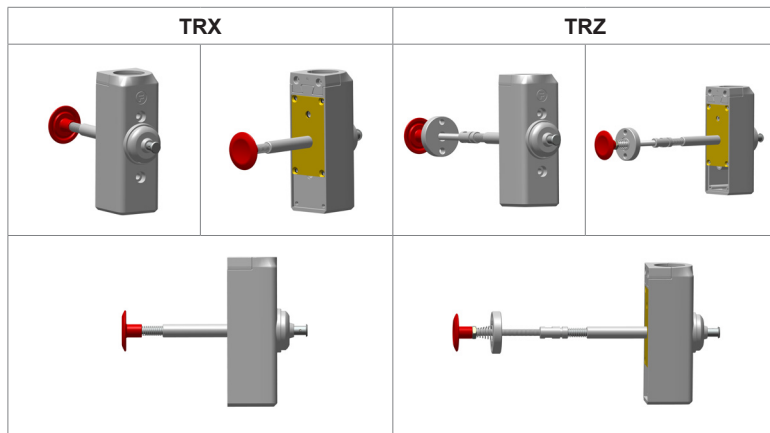

**Internal Release Element**

- Element allows emergency exit even if unit is locked by keys and or solenoid.
- Unit automatically breaks safety circuits and holds them open until unit is reset.
- When present, the push IR always occupies the top element.
- TRX works through wall thickness upto 60mm.
- TRZ allows customer to customise length of emergency release.

Safety Data	
Standards	EN13849-1:2008 EN13849-2:2012 EN62061:2005 EN14119:2013
Certifications	CE marked for all applicable directives
Category	Cat. 4, PLe (EN/ISO 13849-1) and SIL3 (EN/IEC 62061)
Functional Safety Data	B10d 5,000,000

Technical Specification	
Housing Materials	Painted die cast aluminium
Colour	Dark Grey
Ingress Protection	IP65*
Mechanical Life	1,000,000 Operations
Ambient Temperature	-5°C to +40°C (23°F to 104°F)

Internal Release Part Number Options	
Part Number	Description
TRX	Standard 60mm Internal Release
TRZ	Variable length Internal Release

\*IP protection is to the tGard stack that this module attaches to, when correctly fitted according to installation and maintenance instructions.

Dimensional Drawing - TRX

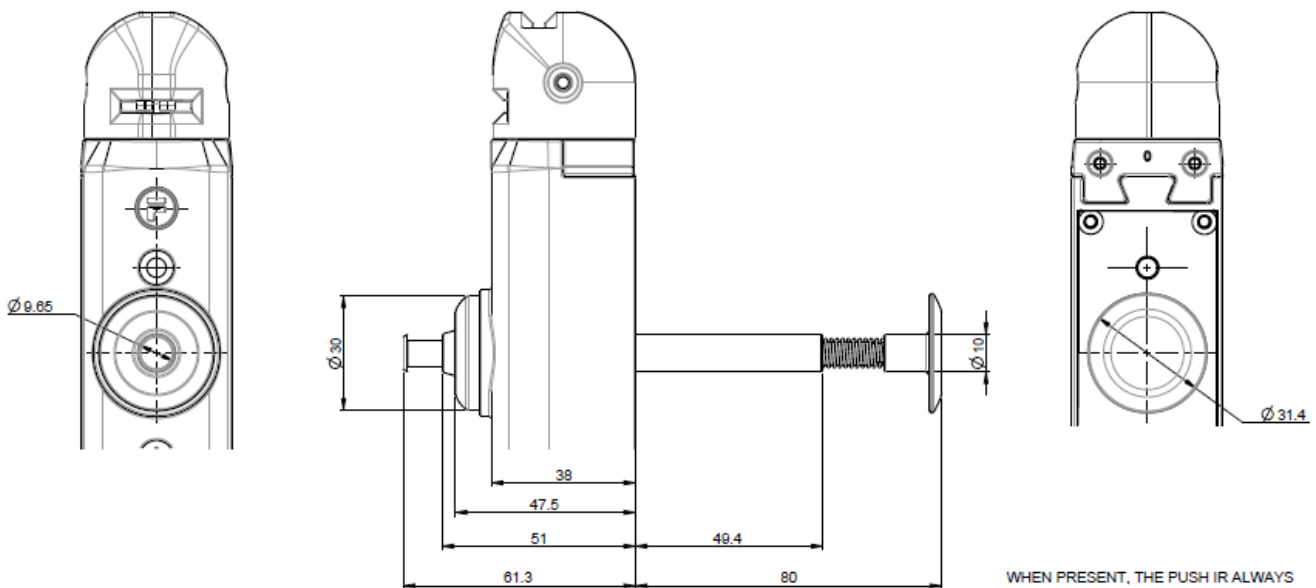

WHEN PRESENT, THE PUSH IR ALWAYS OCCUPIES THE TOP MODULE.

SHORTEST BODY THAT CAN BE USED WITH A PUSH IR IS A 3-WAY (G01-00021).

BOTH BUTTONS SHOWN IN OUT POSITION, APPROX. 9MM OF MOVEMENT WHEN PUSHED.

Internal Release Module

Dimensional Drawing - TRZ

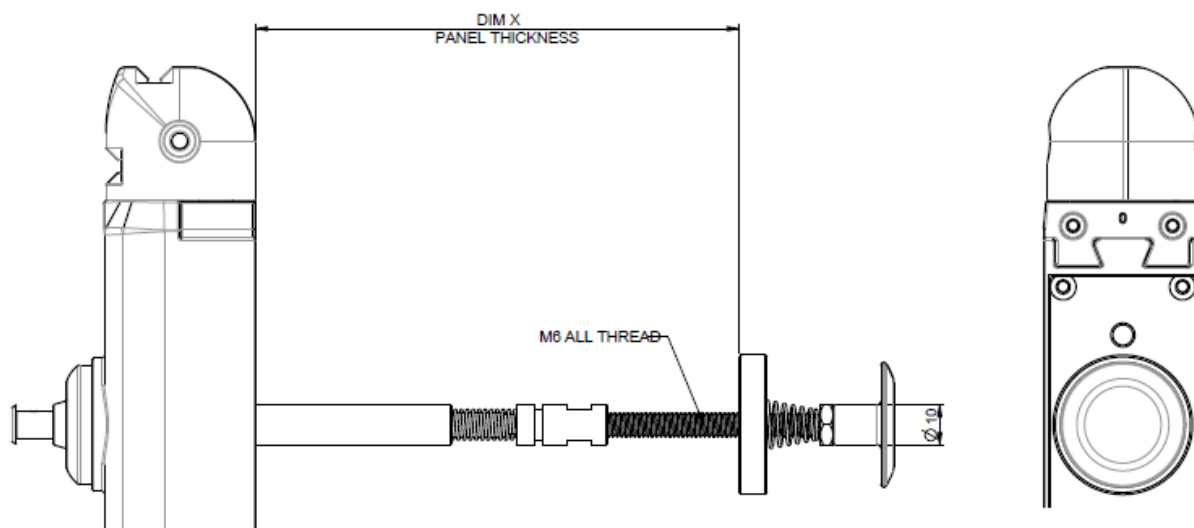

TGARD PUSH IR EXTENSION SUPPORT BOSS

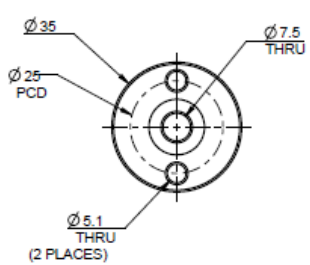



Safety & Access Lock Element

TSN, TGN, TAB, TQB

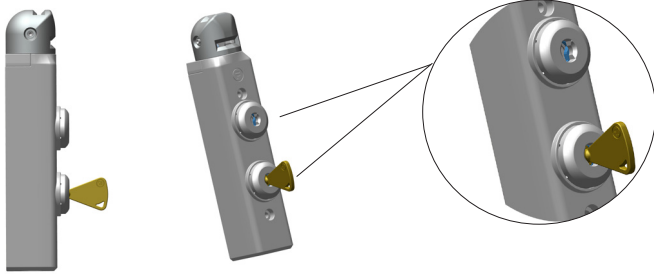

Safety & Access Lock Elements shown in 2 way case with head

**Safety & Access Lock Element**

- Robust radial disc tumbler lock.
- >3000 combinations.
- 10 mastered combinations (can be used with all 3000 individual combinations).
- No key included.
- Max. No. of mechanical locks = 10

**Safety Lock - TSN, TGN**

- Prevent closure of door and start up until key returned.

**Access Lock - TAB, TQB**

- Only allow access with correct key.

**Location**

- Safety Lock must be directly under head / cap (or under internal release element if one is fitted).
- Access keys must be directly under safety locks (or under head or internal release if no safety locks)

**Safety Data**

Standards	EN13849-1:2008 EN13849-2:2012 EN62061:2005 EN14119:2013	
Certifications	CE marked for all applicable directives	
Category	Cat. 4, PLe (EN/ISO 13849-1) and SIL3 (EN/IEC 62061)	
Functional Safety Data	B10d	5,000,000

**Technical Specification**

Housing Materials	Painted die cast aluminium
Colour	Dark Grey
Ingress Protection	IP65*
Operating Force	< 1Nm
Mechanical Life	1,000,000 Operations
Maximum Frequency of Ops	1 per second
Ambient Temperature	-5°C to +40°C (23°F to 104°F)

\*IP protection is to the tGard stack that this module attaches to, when correctly fitted according to installation and maintenance instructions.

**Safety & Access Lock Part Number Options**

Part Number	Description
TSN	Standard Safety Lock (no key)*
TGN	Master Safety Lock (no key)*
TAB	Standard Access Lock (no key)*
TQB	Master Access Lock (no key)*
*Keys Ordered Separately	

Dimensional Drawing

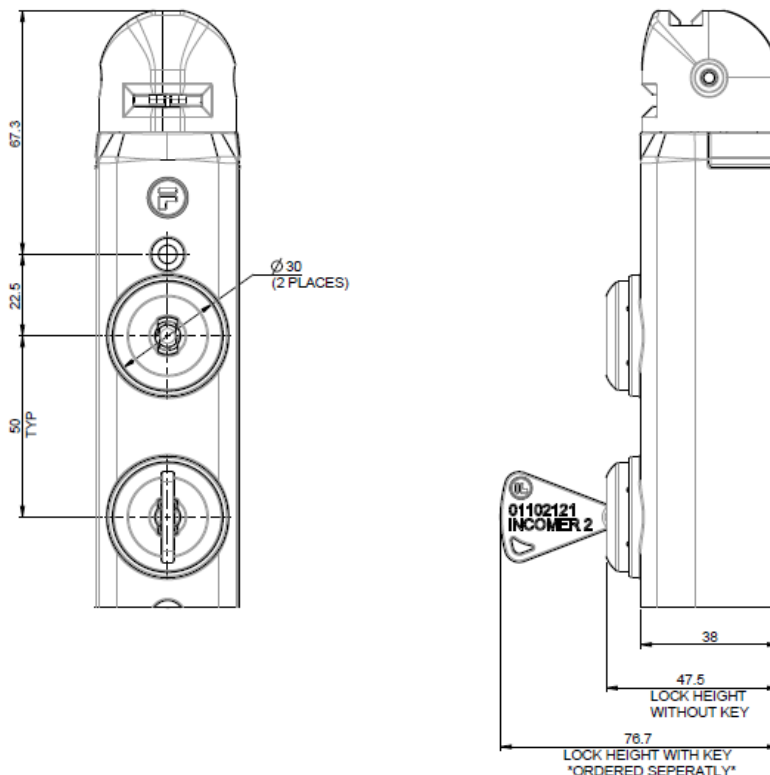

Safety Switch Element

TSM & TSS



TSM



TSS

**Safety Switch Element**

Can be driven by either the operation of the head element (removal of actuator) or a mechanical lock.

- Operates on dual safety circuits.
- 2 positively driven force break NC contacts (uses none of the I/O pins).
- IP65.
- 1 Normally Open (N/O) contact giving 24V signal on I/O pin (TSM only).
- Red LED illumination to show door open (TSM only).

**Location**

- First element after all mechanical elements (Head, Internal Release and Locks).

**Safety Data**

Standards	EN13849-1:2008 EN13849-2:2012 EN62061:2005 EN14119:2013	
Certifications	CE marked for all applicable directives	
Category	Cat. 4, PLe (EN/ISO 13849-1) and SIL3 (EN/IEC 62061)	
Functional Safety Data	B10d	5,000,000

**Technical Specification**

Housing Materials	Painted die cast aluminium
Colour	Dark Grey
Ingress Protection	IP65*
Mechanical Life	1,000,000 Operations
Maximum Frequency of Ops	1 per second
Ambient Temperature	-5°C to +40°C
Switching Principle	Positive Break
Switching Contact Element	2 N/C on Safety Circuits 1 N/O per Monitor (TSM only)
Switching Current	100mA
Voltage	24V DC

**Safety & Control Connector Part Number Options**

Part Number	Description
TSM	Safety Switch
TSS	Safety Switch - No N/O monitor contact

**Electrical Guidance**

Part No.	Inputs	Outputs	Module operates on the safety circuits	Order of pin assignment from base to head
TSM	0	1	Yes	-
TSS	0	0	Yes	-

\*IP protection is to the tGard stack that this module attaches to, when correctly fitted according to installation and maintenance instructions.

Dimensional Drawing - TSM, TSS

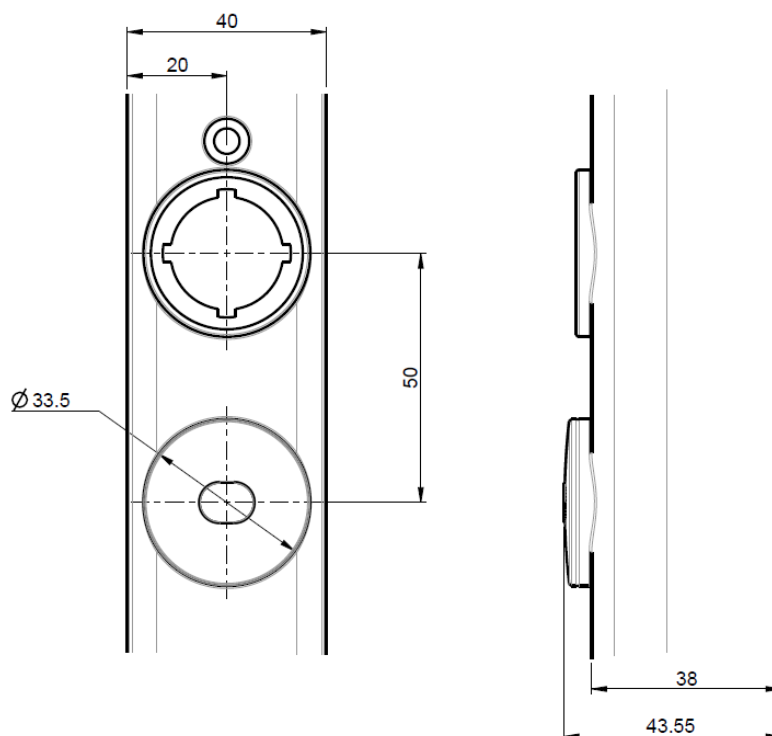

Solenoid Controlled Lock & Safety Switch Elements

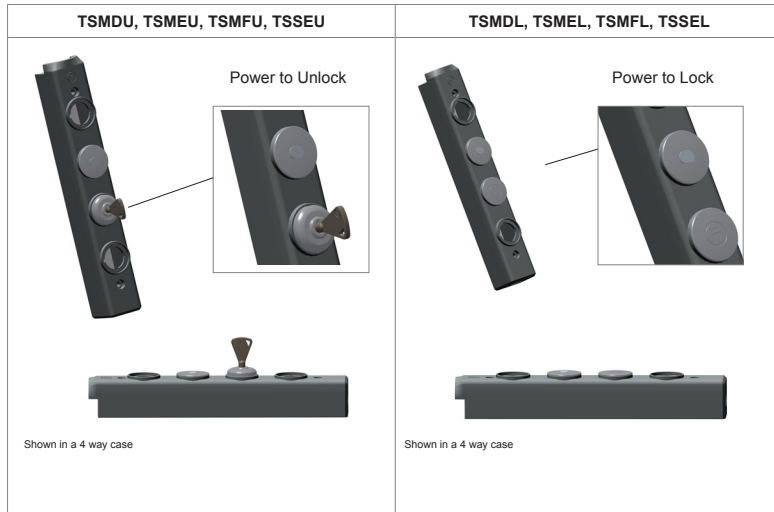

- TSS or TSM element incorporated to give dual safety circuits monitoring the door (or key) as well as 1 x N/O contact output (TSM only) for door monitoring (high when door open) and status LED. (Red when door open, TSM only).
  - 1 input used to energise solenoid.
  - Power to Lock and Power to Unlock options available.
  - 3 options for solenoid.
    - TDU/L - Dual safety circuits wired in series with TSM dual safety circuits.
    - TEU/L - No safety circuits for solenoid (solenoid monitor switch gives 24V on locked position)
    - TFU/L - Dual safety circuits giving independent safety monitoring on solenoid in addition to TSS.
  - 1 x N/O contact output for solenoid monitoring (high when unlocked) and status LED. (Green when locked).
  - Solenoid override key provided with power to unlock units.
- Location**
- First element after all mechanical elements (Head, Internal Release and Locks).

Safety Data	
Standards	EN13849-1:2008 EN13849-2:2012 EN62061:2005 EN14119:2013
Certifications	CE marked for all applicable directives
Category	Cat. 4, PL e (EN/ISO 13849-1) and SIL3 (EN/IEC 62061)
Functional Safety Data	B10d 5,000,000

Technical Specification	
Housing Materials	Painted die cast aluminium
Colour	Dark Grey
Ingress Protection	IP65*
Retention Force Locked	2500N
Mechanical Life	1,000,000 Operations
Electrical Life	1,000,000 Operations
Maximum Frequency of Ops	1 per second
Ambient Temperature	-5°C to +40°C
Switching Contact Element	2 x 2 N/C on Safety Circuits

\*IP protection is to the tGard stack that this module attaches to, when correctly fitted according to installation and maintenance instructions.

Part Number Options	
Part Number	Description
TSMDU	Power to Unlock - head & solenoid safety in series
TSMDL	Power to Lock - head & solenoid safety in series
TSMEU	Power to Unlock - safety on head element only
TSMEL	Power to Lock - safety on head element only
TSMFU	Power to Unlock - four safety circuits
TSMFL	Power to Lock - four safety circuits
TSSEU	Power to Unlock - safety on head element only (no monitoring contact on head)
TSSEL	Power to Lock - safety on head element only (no monitoring contact on head)

Electrical Guidance											
Part No.	Inputs	Outputs	Safety Circuits	Solenoid Type	Solenoid Monitor Signal	Part No.	Inputs	Outputs	Safety Circuits	Solenoid Type	Solenoid Monitor Signal
TSMDU	1	2	2 = Head & Sol in Series	Power to Unlock	24V on Unlock	TSMFU	1	2	4 = Head & Sol separate	Power to Unlock	24V on Unlock
TSMDL	1	2	2 = Head & Sol in Series	Power to Lock	24V on Unlock	TSMFL	1	2	4 = Head & Sol separate	Power to Lock	24V on Unlock
TSMEU	1	2	2 = Head Only	Power to Unlock	24V on Lock	TSSEU	1	1	2 = Head Only	Power to Unlock	24V on Lock
TSMEL	1	2	2 = Head Only	Power to Lock	24V on Lock	TSSEL	1	1	2 = Head Only	Power to Lock	24V on Lock

Dimensional Drawing - TSMDU, TSMEU, TSMFU, TSSEU

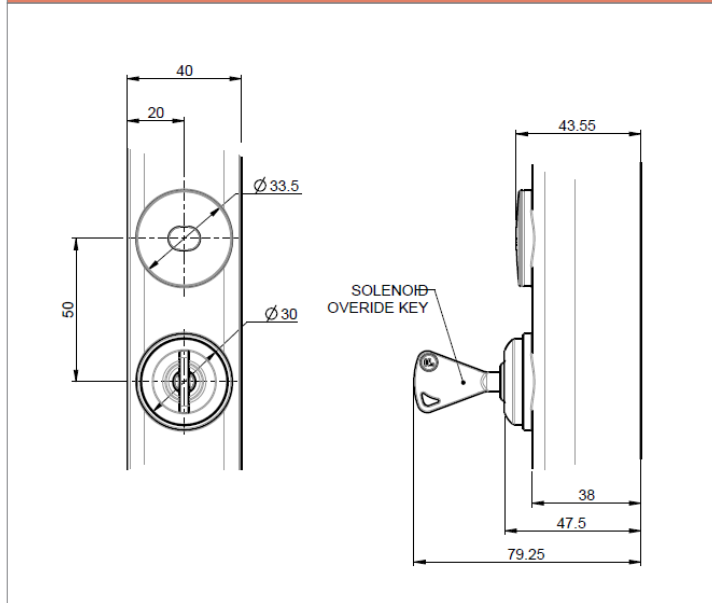

Dimensional Drawing - TSMDL, TSMEL, TSMFL, TSSEL

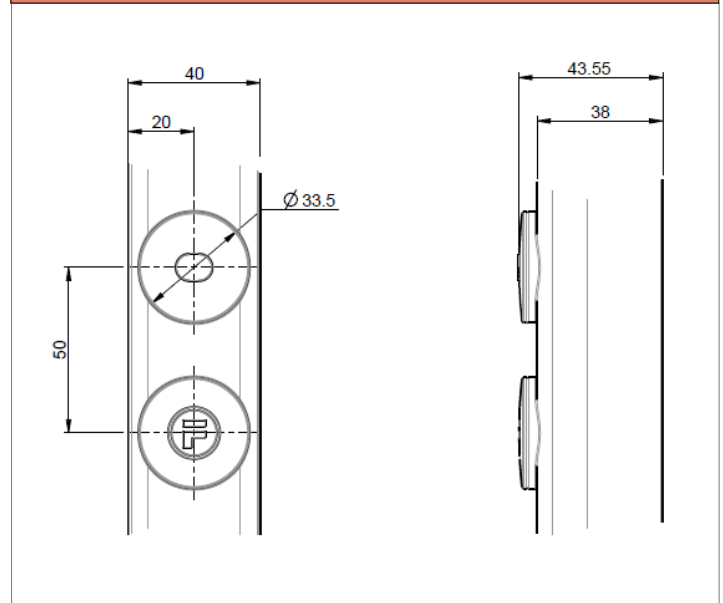

Emergency Stop Element

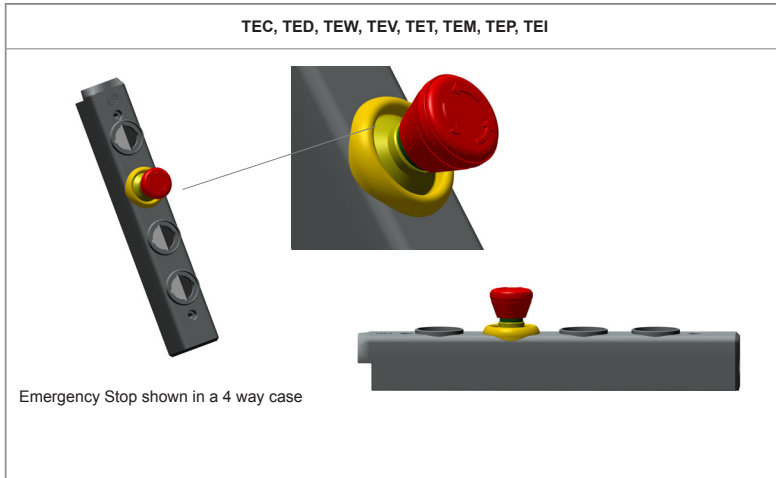

**Emergency Stop Element**

Emergency stop element, version available with a monitoring contact or illumination.

- 2 positively driven force break N/C Safety contacts (uses none of the I/O pins (TEC / TEV)
- Monitored version also has 1 output signal and this uses 1 output pin.
- Illuminated version also has 1 input signal and this uses 1 input pin (it is illuminated by the controlling PLC, not by the action of pressing the e-stop).
- e-Stop is always mounted at the top of any control elements, but below solenoid / head / safety switches / locks.
- TED/C/W/V safety contacts are wired in series with another element in the stack e.g. TSS, to reduce pin requirements.
- TET/M/P/I safety contacts are wired separately to all other elements in the stack.

Safety Data		
Standards	EN60947-5-1:2007 EN13849-1:2008 EN13849-2:2012 EN62061:2005	
Certifications	CE marked for all applicable directives	
Category	Cat. 4, PLe (EN/ISO 13849-1) and SIL3 (EN/IEC 62061)	
Functional Safety Data	B10d	5,000,000
	DC	High 99% (with correct monitoring)

Technical Specification	
Housing Materials	Painted die cast aluminium
Colour	Red, Yellow & Dark Grey
Ingress Protection	IP65*
Ambient Temperature	-5°C to +40°C
Switches Conformance	IEC 60947-5-1
Switching Contact Element	2 N/C (safety circuits)
Switching Principle	Positive Break
Switching Current	100mA
Switching Voltage	24V

Emergency Stop Part Number Options				
Part Number	Reset	Illuminated	Monitored	Wiring
TEC	Twist	-	-	Series
TED	Twist	-	Yes	Series
TEW	Pull	-	-	Series
TEV	Twist	Yes	-	Series
TET	Twist	-	-	Separate
TEM	Twist	-	Yes	Separate
TEP	Pull	-	-	Separate
TEI	Twist	Yes	-	Separate



Electrical Guidance			
Part No.	Inputs	Outputs	Elements operate on the safety circuits
TEC	0	0	Series
TED	0	1	Series
TEW	0	0	Series
TEV	1	0	Series
TET	0	0	Separate
TEM	0	1	Separate
TEP	0	0	Separate
TEI	1	0	Separate

\*IP protection is to the tGard stack that this module attaches to, when correctly fitted according to installation and maintenance instructions.

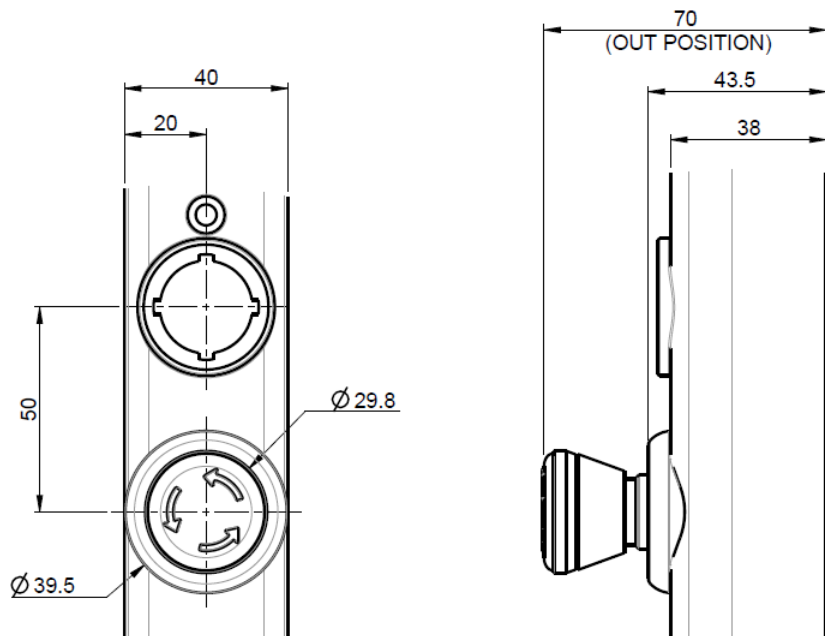
Dimensional Drawing - TEC, TED, TEW, TEV, TET, TEM, TEP, TEI

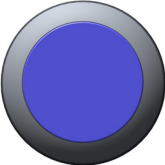
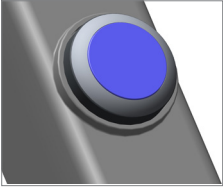

Blue Re-start Switch Element

TSR		
		 <p style="font-size: small; text-align: center;">Image of Blue Re-start switch in tGard case</p>
<p><b>Laser Engraving Information</b> Engraving for each button is 2 lines of 8 characters</p>		<ul style="list-style-type: none"> <li>Blue Re-start switch operating on 1 Normally Open (N/O) and 1 Normally Closed (N/C).</li> <li>For safety relay reset.</li> <li>Works on own separate dual safety circuit.</li> <li>Safety circuit 1 opens on button depression.</li> </ul> <p>Location</p> <ul style="list-style-type: none"> <li>Highest control element after e-Stop's.</li> </ul>

Safety Data	
Standards	EN60957-5-1:2009 (Low-voltage switchgear and control gear).
Certifications	CE marked for all applicable directives
Functional Safety Data	B10d <span style="float: right;">1,300,000</span>

Technical Specification	
Housing Materials	Painted die cast aluminium
Colour	Dark Grey
Ingress Protection	IP65*
Mechanical Life	1,000,000 Operations
Electrical Life	1,000,000 Operations
Ambient Temperature	-5°C to +40°C
Switches Conformance	IEC 60947-5-1
Switching Contact Element	1 N/O / 1 N/C
Switching Principle	Positive Break
Switching Current	100mA
Switching Voltage	24V
Isolating Distance	2mm per switch element
Contact Material	90% Silver & 10% Nickel

Part Number Options	
Part Number	Description
TSR	Start Re-start Switch - Blue







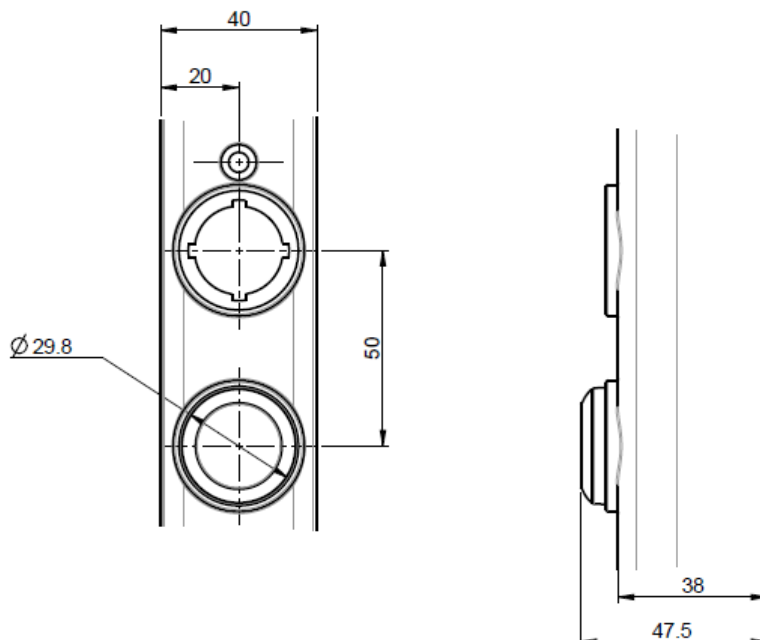





Electrical Guidance			
Inputs	Outputs	Module operates on the safety circuits	Order of pin assignment from base to head
0	0	Yes	-

\*IP protection is to the tGard stack that this module attaches to, when correctly fitted according to installation and maintenance instructions.

Dimensional Drawing - TSR



1 Normally Open (N/O) Illuminating Switches - Push, Selector, Momentary & Latching

Illuminated Pushbuttons		TP1	TP2	TP3	TP6	TP7
						
Illuminated Pushbuttons - Protruding		TG1	TG2	TG3	TG6	TG7
						
2 Position Illuminated Selector Switch		T2E / T2F	<b>Laser Engraving Information</b> Engraving for each button is 2 lines of 8 characters.  Laser engraving not available on Selector Switches.			

1 Normally Open (N/O) Illuminated Switch for machine control.

- Each switch uses 1 input and 1 output pin.
- Inputs to the tGard stack are always assigned before outputs.
- High input will illuminate the lamp, irrespective of selector.
- Range of options.
  - Push Button
  - Protruding Push Button
  - 2 Position Selector Switches
    - Latching
    - Momentary

Safety Data	
Standards	EN60957-5-1:2009 (Low-voltage switchgear and control gear).
Certifications	CE marked for all applicable directives

Technical Specification	
Housing Materials	Painted die cast aluminium
Colour	Dark Grey
Ingress Protection	IP65*
Mechanical Life	1,000,000 Operations
Electrical Life	1,000,000 Operations
LED Life	100,000 hours on time
Ambient Temperature	-5°C to +40°C
Switching Contact Element	1 output
Switching Current	100mA
Switching Voltage	24V

Part Number Options	
Part Number	Description
TP1	Illuminated Push Button - Red
TP2	Illuminated Push Button - Yellow
TP3	Illuminated Push Button - Green
TP6	Illuminated Push Button - Blue
TP7	Illuminated Push Button - White
TG1	Protruding Illuminated Push Button- Red
TG2	Protruding Illuminated Push Button- Yellow
TG3	Protruding Illuminated Push Button- Green
TG6	Protruding Illuminated Push Button- Blue
TG7	Protruding Illuminated Push Button- White
T2E	2 Position Illuminated Selector Switch - Latching
T2F	2 Position Illuminated Selector Switch - Momentary

Electrical Guidance			
Inputs	Outputs	Module operates on the safety circuits	Order of pin assignment from base to head
1	1	No	Input (LED) assigned first

\*IP protection is to the tGard stack that this module attaches to, when correctly fitted according to installation and maintenance instructions.

Dimensional Drawing - TP1, TP2, TP3, TP6, TP7

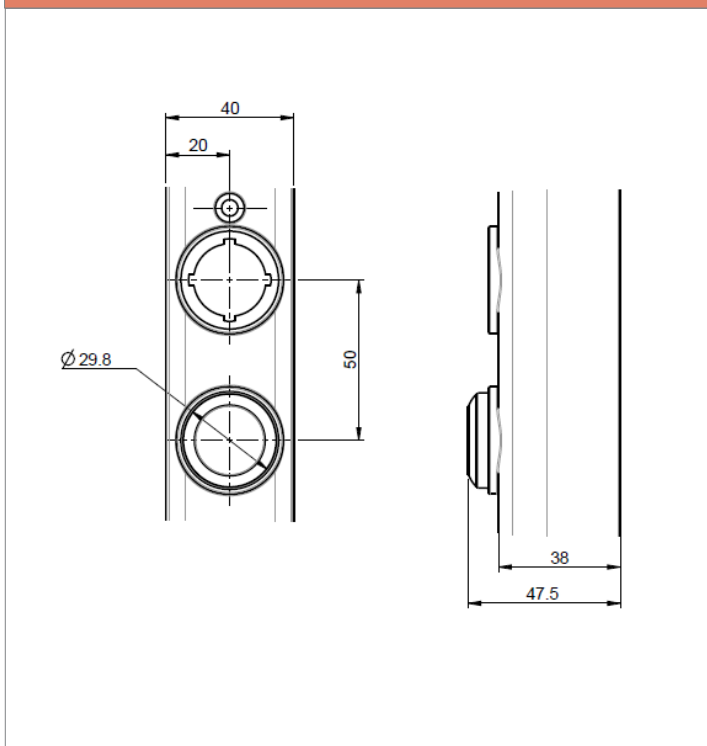

Dimensional Drawing - TG1, TG2, TG3, TG6, TG7

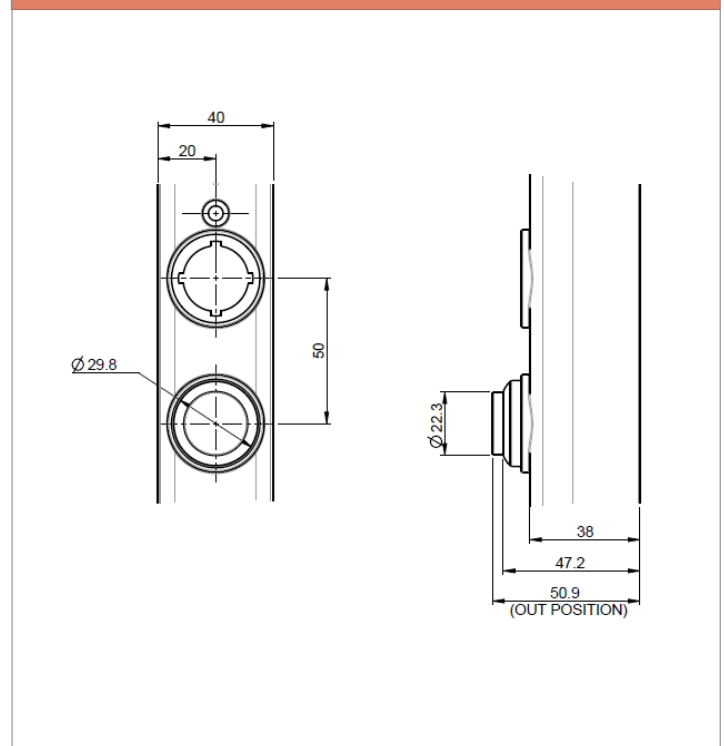

1 Normally Open (N/O) Illuminating Switches - Push, Selector, Momentary & Latching

Dimensional Drawing - T2E, T2F

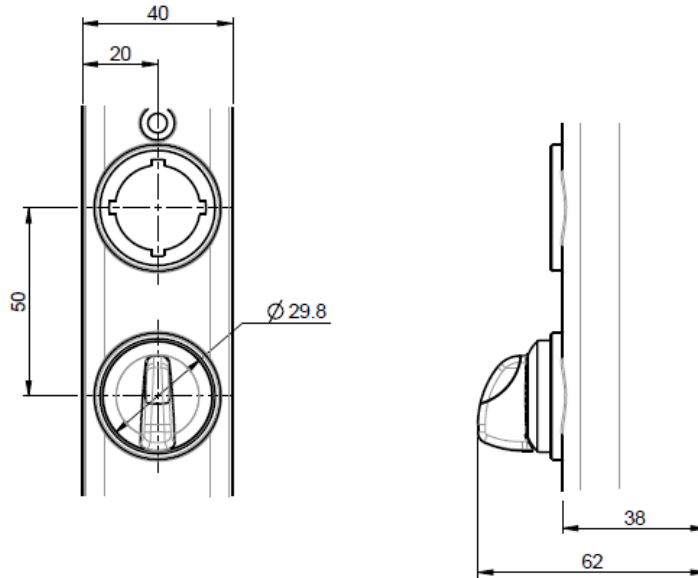

1 Normally Open (N/O) Non-illuminating Switches - Push, Selector, Key, Momentary & Latching

Pushbuttons		TPB	TPR	TPG	TPW	TPY	TPZ
Pushbuttons - Protruding		TGB	TGR	TGG	TGW	TGY	TGZ
2 Position Selector Switch		T2A / T2D		<b>Laser Engraving Information</b> Engraving for each button is 2 lines of 8 characters. 			
2 Position Selector Key Switch		TK1 / TK3					

1 N/O Switch for machine control.

- Each switch uses 1 output pin.
- Range of options.
  - Push Button
  - Protruding Push Button
  - 2 Position Selector Switches
    - Latching
    - Momentary
    - Key Latching
    - Key Momentary

**Part Number Options**

Part Number	Description
TPB	Push Button - Black
TPR	Push Button - Red
TPG	Push Button - Green
TPW	Push Button - White
TPY	Push Button - Yellow
TPZ	Push Button - Blue
TGB	Push Button Protruding - Black
TGR	Push Button Protruding - Red
TGG	Push Button Protruding - Green
TGW	Push Button Protruding - White
TGY	Push Button Protruding - Yellow
TGZ	Push Button Protruding - Blue
T2A	2 Position Selector Switch - Latching
T2D	2 Position Selector Switch - Momentary
TK1	2 Position Selector Key Switch - Latching
TK3	2 Position Selector Key Switch - Momentary

Safety Data	
Standards	EN60957-5-1:2009 (Low-voltage switchgear and control gear).
Certifications	CE marked for all applicable directives

Technical Specification	
Housing Materials	Painted die cast aluminium
Colour	Dark Grey
Ingress Protection	IP65*
Mechanical Life	1,000,000 Operations
Electrical Life	1,000,000 Operations
Maximum Frequency of Ops	1 per second
Ambient Temperature	-5°C to +40°C
Switching Contact Element	1 output
Switching Current	100mA
Switching Voltage	24V

Electrical Guidance			
Inputs	Outputs	Module operates on the safety circuits	Order of pin assignment from base to head
0	1	No	-

\*IP protection is to the tGard stack that this module attaches to, when correctly fitted according to installation and maintenance instructions.

Dimensional Drawing - TPB, TPR, TPG, TPW, TPY, TPZ

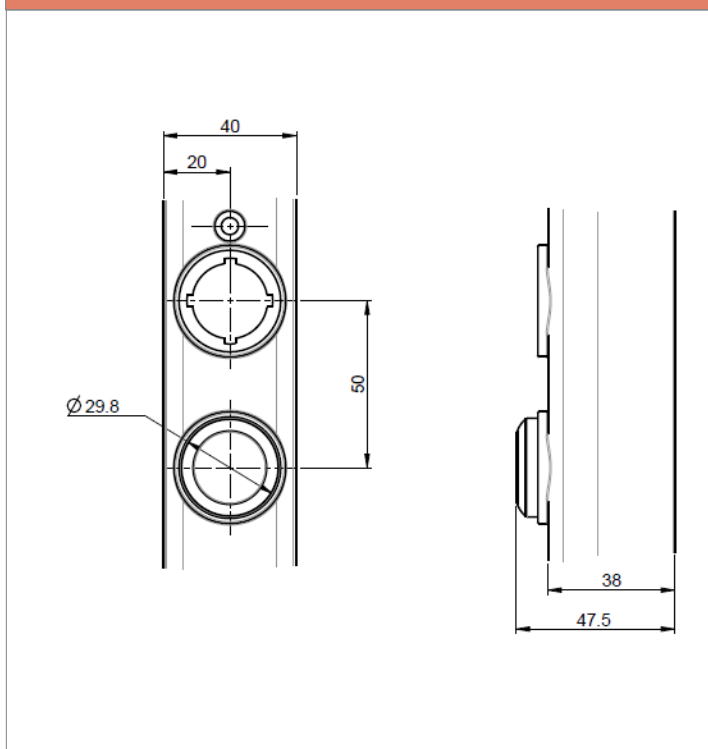

Dimensional Drawing - TGB, TGR, TGG, TGW, TGY, TGZ

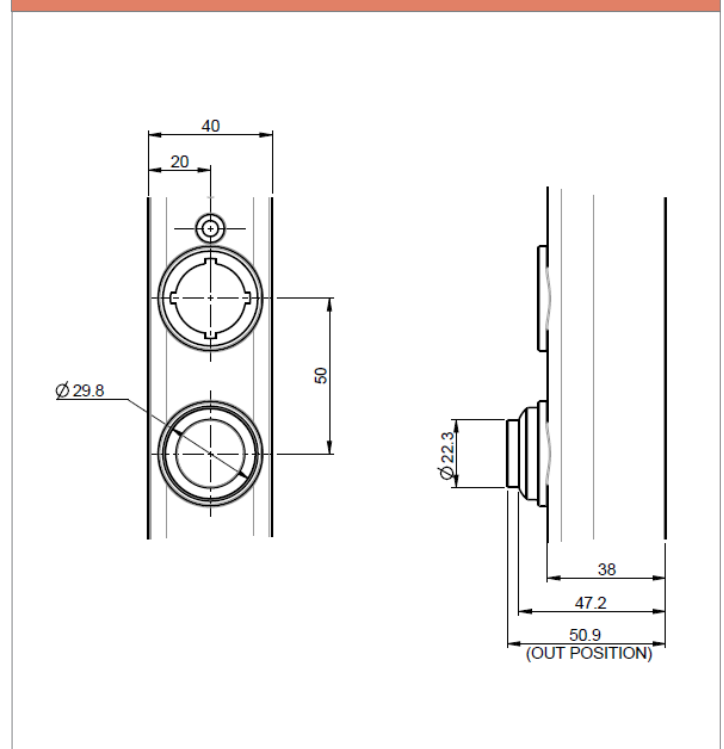



1 Normally Open (N/O) Non-illuminating Switches - Push, Selector, Key, Momentary & Latching

Dimensional Drawing - T2A, T2D

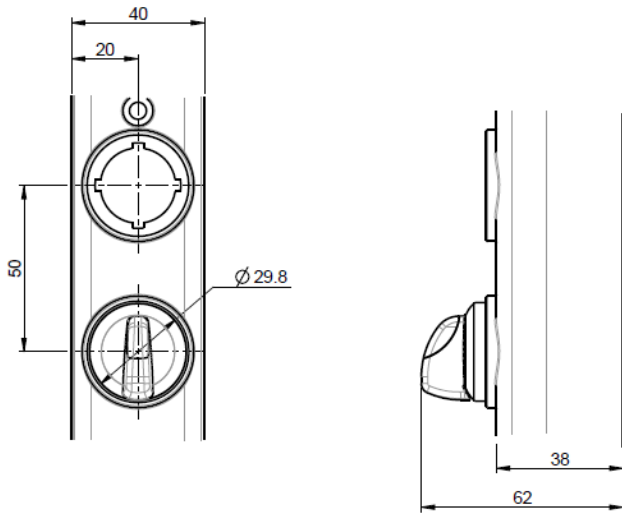

Dimensional Drawing - TK1, TK3

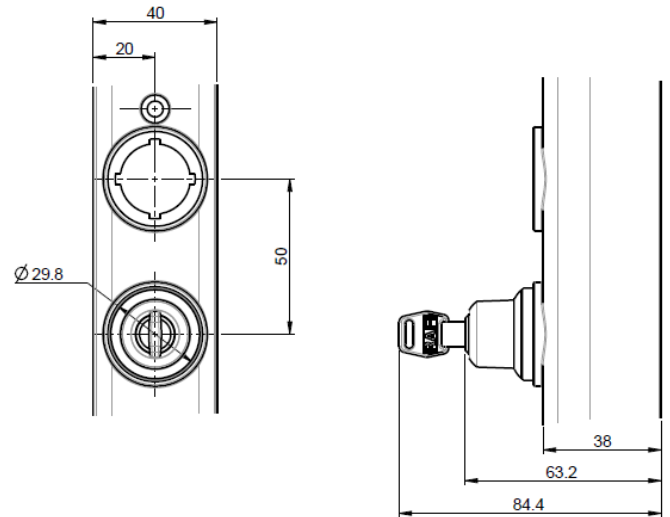

LED Lamp Element

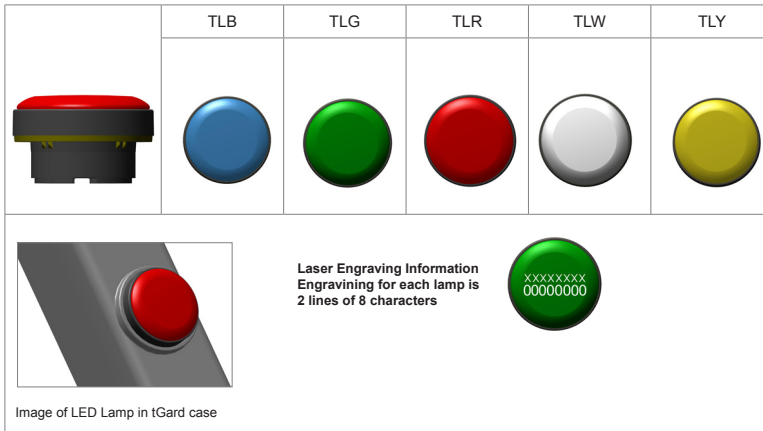

**LED Lamp Element**

Lamp element for status indication can be configured to indicate machine status.

- LED status indicator
- Each lamp uses 1 input pin

Technical Specification	
Housing Materials	Painted die cast aluminium
Colour	Dark Grey
Ingress Protection	IP65*
Ambient Temperature	-5°C to +40°C
LED Life	100,000 hours on time

Electrical Guidance			
Inputs	Outputs	Element operates on the safety circuits	Order of pin assignment from base to head
1	0	No	-

LED Lamp Part Number Options	
Part Number	Colour
TLB	Blue
TLG	Green
TLR	Red
TLW	White
TLY	Yellow

\*IP protection is to the tGard stack that this module attaches to, when correctly fitted according to installation and maintenance instructions.

Dimensional Drawing - TLB, TLG, TLR, TLW, TLY

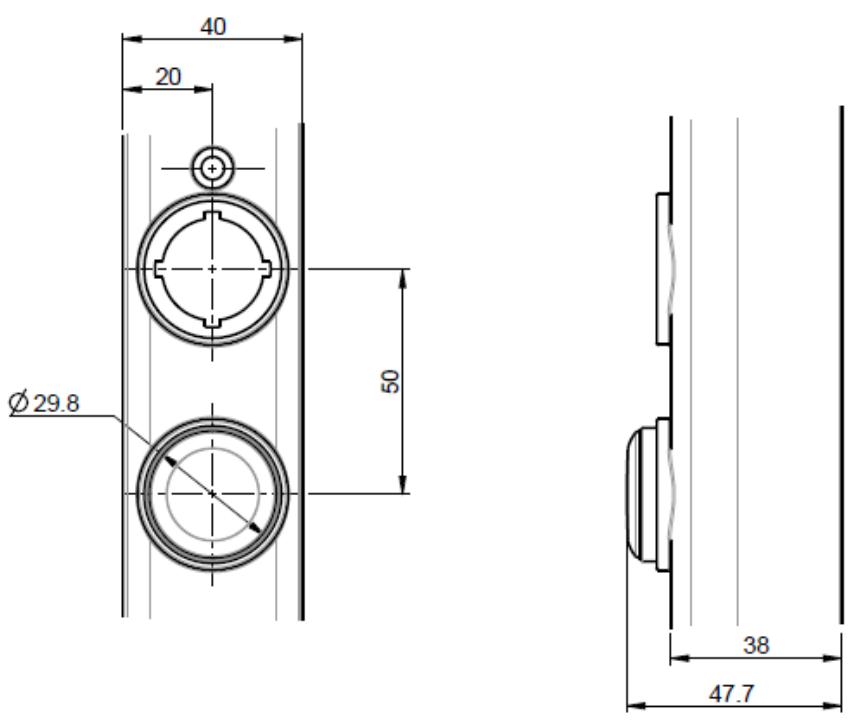

3 Position Selector Switches - Latching & Momentary

T3A, T3D, T3E, T3F



Image of selector switch in tGard case

Each 3 position selector switch uses 2 output pins.

- Clockwise operation sets the lower assigned output High.
- Middle position - output pins Low.
- Anti-clockwise sets higher assigned output High.
- Non-latching - spring return to original position.
- Illumination (when selected) uses 1 input pin.
- Inputs to the tGard stack are always assigned before outputs.

**Safety Data**

Standards	EN60957-5-1:2009 (Low-voltage switchgear and control gear).
Certifications	CE marked for all applicable directives

**Electrical Guidance**

Part No	Inputs	Outputs	Module operates on the safety circuits	Order of pin assignment from base to head
T3A	0	2	No	Clockwise output assigned first
T3D	0	2	No	Clockwise output assigned first
T3E	1	2	No	LED output assigned first Clockwise output assigned second Anti-clockwise output assigned Third
T3F	1	2	No	LED output assigned first Clockwise output assigned second Anti-clockwise output assigned Third

**Technical Specification**

Housing Materials	Painted die cast aluminium
Colour	Dark Grey
Ingress Protection	IP65*
Mechanical Life	1,000,000 Operations
Electrical Life	1,000,000 Operations
LED Life	100,000 hours on time
Ambient Temperature	-5°C to +40°C
Switches Conformance	IEC 60947-5-1
Switching Contact Element	2 outputs
Switching Current	100mA
Switching Voltage	24V

\*IP protection is to the tGard stack that this module attaches to, when correctly fitted according to installation and maintenance instructions.

**3 Position Selector Switch Part Number Options**

Part Number	Description
T3A	Latching (Both Sides)
T3D	Momentary
T3E	Latching (Both Sides) Illuminated
T3F	Momentary Illuminated

Dimensional Drawing - T3A, T3D, T3E, T3F

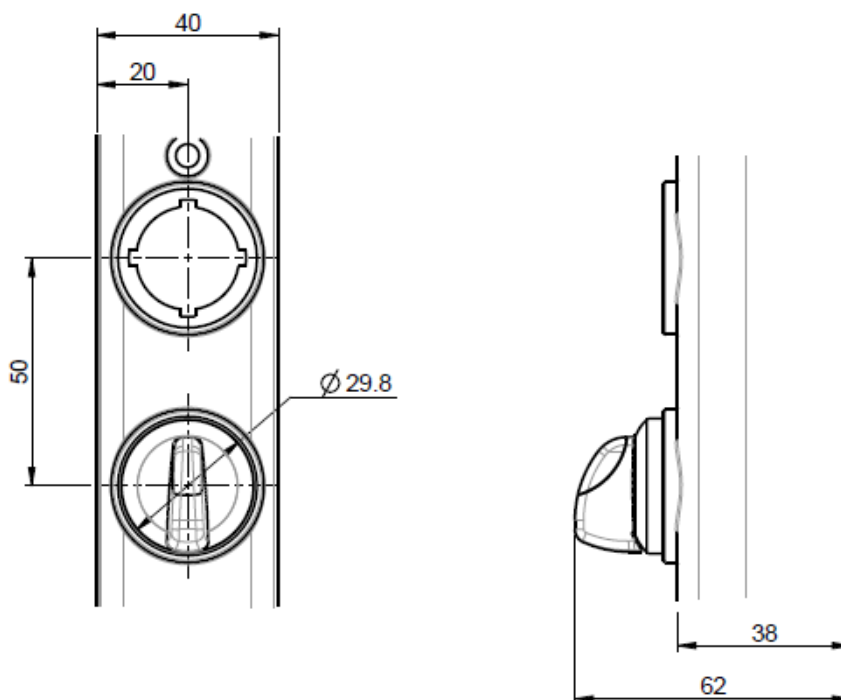

Foot

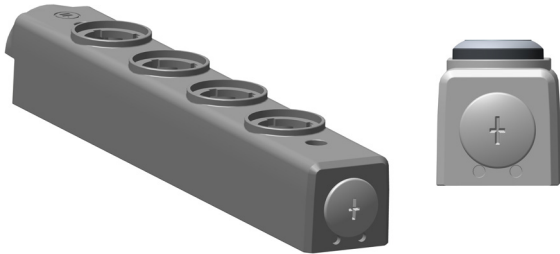

**Foot**

For terminating purely mechanical configurations (no wiring).

Technical Specification	
Housing Materials	Painted die cast aluminium
Colour	Dark Grey
Ambient Temperature	-5°C to +40°C (23°F to 104°F)

Actuator Part Number Options	
Part Number	Description
TBF	Foot

\*IP protection is to the tGard stack that this module attaches to, when correctly fitted according to installation and maintenance instructions.

Dimensional Drawing - TBF

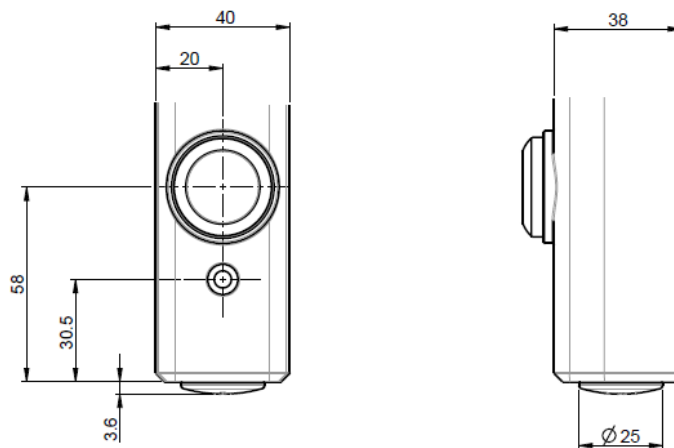

Safety & Control Connector

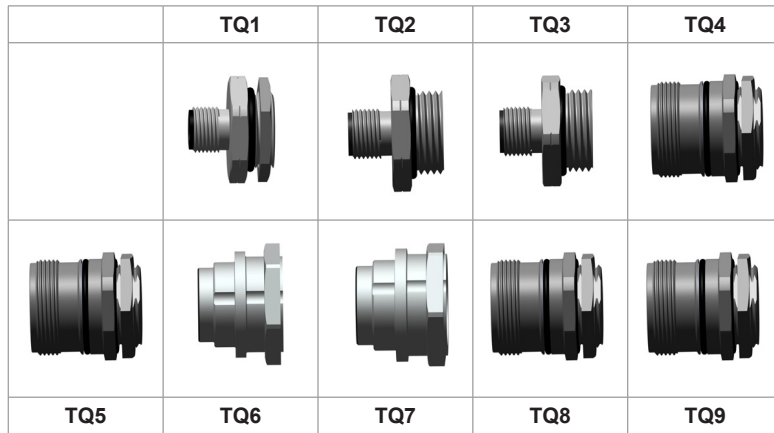

**Safety & Control Connector**

- Safety Only, Control Only or Safety & Control.
- 5/8/12/14/19 pin depending on need.
- Dual safety available on request.

Technical Specification	
Ingress Protection	IP65*
Ambient Temperature	-5°C to +40°C
Voltage	24V DC

\*IP protection is to the tGard stack that this module attaches to, when correctly fitted according to installation and maintenance instructions.

Safety & Control Connector Part Number Options			
Part Number	Description	Part Number	Description
TQ1	5 Pin QD Safety Only	TQ6	14 Pin QD Safety & Control
TQ2	8 Pin QD Control Only	TQ7	14 Pin QD Safety & Control (up to 3 modules)
TQ3	8 Pin QD Safety & Control	TQ8	19 Pin QD Safety & Control
TQ4	12 Pin QD Control Only	TQ9	19 Pin QD Dual Safety & Control
TQ5	12 Pin QD Safety & Control		

Pins										
Part No.	TQ1	TQ2	TQ3	TQ4	TQ5	TQ6	TQ7	TQ8	TQ9	Pin Assignment
Number of Pins	5	8	8	12	12	14	14	19	19	
Connector Size	M12	M12	M12	M23	M23	7/8" UN2	7/8" UN2	M23	M23	
# of Safety Circuits	2	0	2	0	2	2	2	2	4	
# of Control I/O	0	5	1	9	5	7	7	12	8	
	SC 1	I/O 0	SC 1	+24v	+24v	I/O 3	I/O 3	SC 1	SC 1	1
	SC 2	+24v	+24v	I/O 0	SC 1	I/O 2	I/O 2	SC 2	SC 2	2
	SC 1	Earth	Earth	0 v	0 v	I/O 1	I/O 1	SC 1	SC 1	3
	SC 2	I/O 1	SC 2	I/O 1	SC 2	+24v	+24v	SC 2	SC 2	4
	Earth	I/O 2	SC 1	I/O 2	SC 1	SC 2	SC 2	I/O 0	I/O 0	5
		I/O 3	SC 2	I/O 3	SC 2	0 v	0 v	0 v	0 v	6
		0v	0 v	I/O 4	I/O 0	I/O 6	I/O 6	I/O 1	I/O 1	7
		I/O 4	I/O 0	I/O 5	I/O 1	I/O 5	I/O 5	I/O 2	I/O 2	8
				I/O 6	I/O 2	I/O 4	I/O 4	I/O 3	I/O 3	9
				I/O 7	I/O 3	SC 1	SC 1	I/O 4	I/O 4	10
				I/O 8	I/O 4	I/O 0	I/O 0	I/O 5	I/O 5	11
				Earth	Earth	SC 2	SC 2	Earth	Earth	12
						SC1	SC 1	I/O 6	I/O 6	13
						Earth	Earth	I/O 7	I/O 7	14
								I/O 8	SC 3	15
								I/O 9	SC 4	16
								I/O 10	SC 3	17
								I/O 11	SC 4	18
								+24v	+24v	19

Use TQ7 for stacks with 3 or less push buttons

Safety & Control Connector

Dimensional Drawing - TQ1, TQ2, TQ3

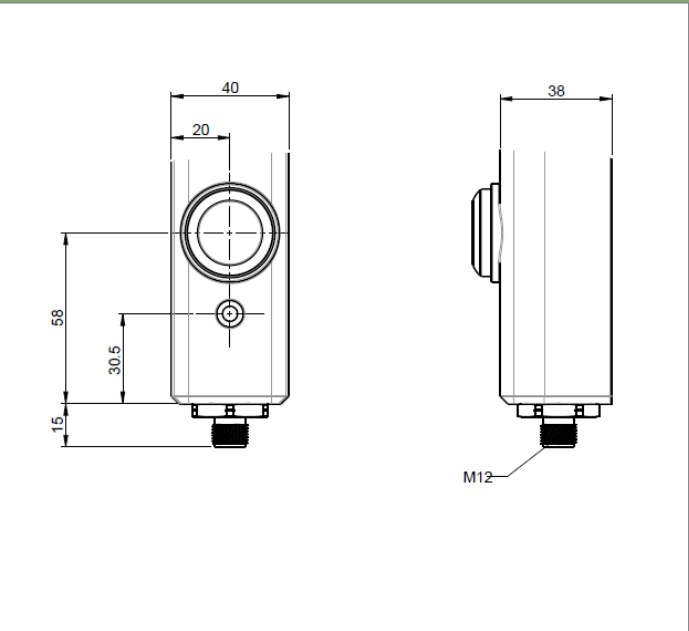

Dimensional Drawing - TQ4, TQ5

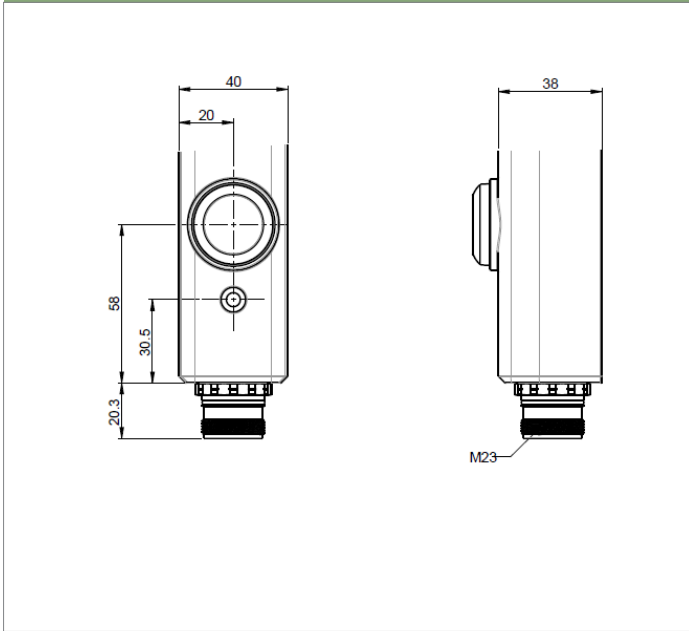

Dimensional Drawing - TQ6, TQ7

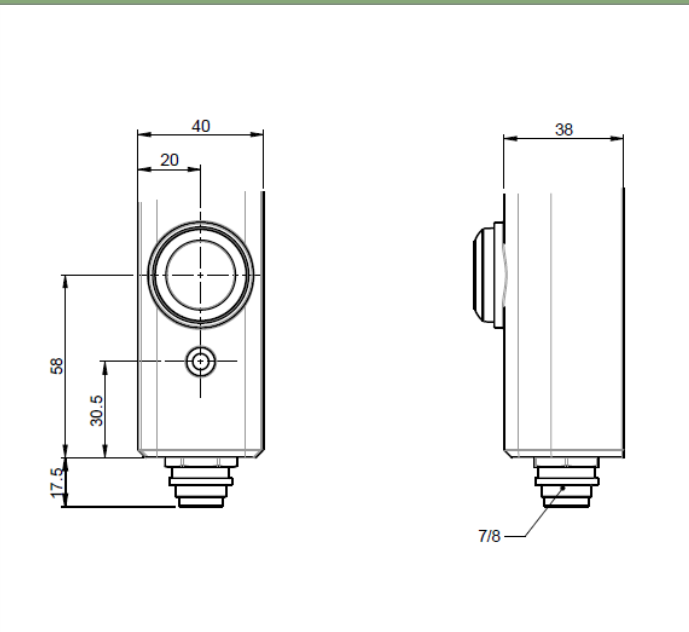

Dimensional Drawing - TQ8, TQ9

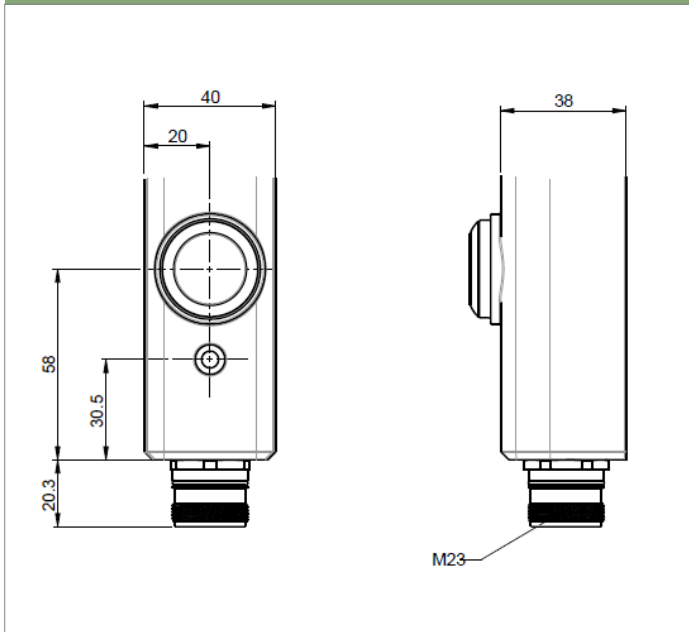

Self Wire Connector

TW1, TW2, TW3



**Self Wire Connector**

- For applications where the customer wishes to make their own connections.
- Push fit terminals.
- Cable size 26-14 AWG.
- Available with 12 or 24 connections.
- Control only and Safety and Control versions available.
- M20 gland thread.
- Requires no additional mounting to frame.

**Technical Specification**

Housing Materials	Painted die cast aluminium
Colour	Dark Grey
Ambient Temperature	-5°C to +40°C (23°F to 104°F)
Ingress Protection	IP65*
Voltage	24V DC

**Actuator Part Number Options**

Part Number	Description
TW1	12 Terminals - Safety & Control
TW2	12 Terminals - Control Only
TW3	24 Terminals - Dual Safety & Control

\*IP protection is to the tGard stack that this module attaches to, when correctly fitted according to installation and maintenance instructions.

**Pins**

Part No.	TW1	TW2	TW3	Pin Assignments
Number of Pins	12 + Earth	12 + Earth	24 + Earth	
# of Safety Circuits	2	0	4	
# of Control I/O	6	10	14	
	+ 24v	+ 24v	+ 24v	1
	0 v	0 v	0 v	2
	SC1	I/O 0	SC1	3
	SC2	I/O 1	SC2	4
	SC1	I/O 2	SC1	5
	SC2	I/O 3	SC2	6
	I/O 0	I/O 4	I/O 0	7
	I/O 1	I/O 5	I/O 1	8
	I/O 2	I/O 6	I/O 2	9
	I/O 3	I/O 7	I/O 3	10
	I/O 4	I/O 8	I/O 4	11
	I/O 5	I/O 9	I/O 5	12
			I/O 6	13
			I/O 7	14
			I/O 8	15
			I/O 9	16
			I/O 10	17
			I/O 11	18
			I/O 12	19
			I/O 13	20
			SC3	21
			SC4	22
			SC3	23
			SC4	24
	Earth	Earth	Earth	

12 way PCB Assembly

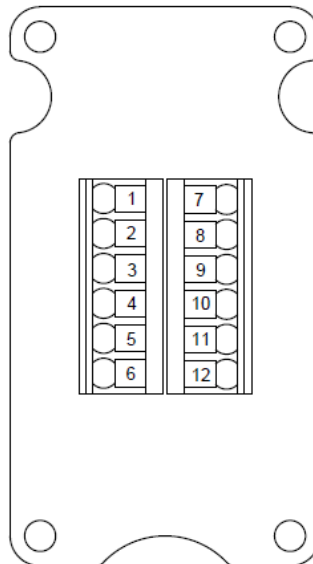

24 way PCB Assembly

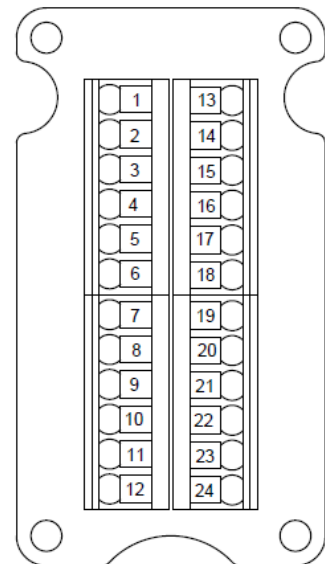

Dimensional Drawing - TW1, 2 & 3

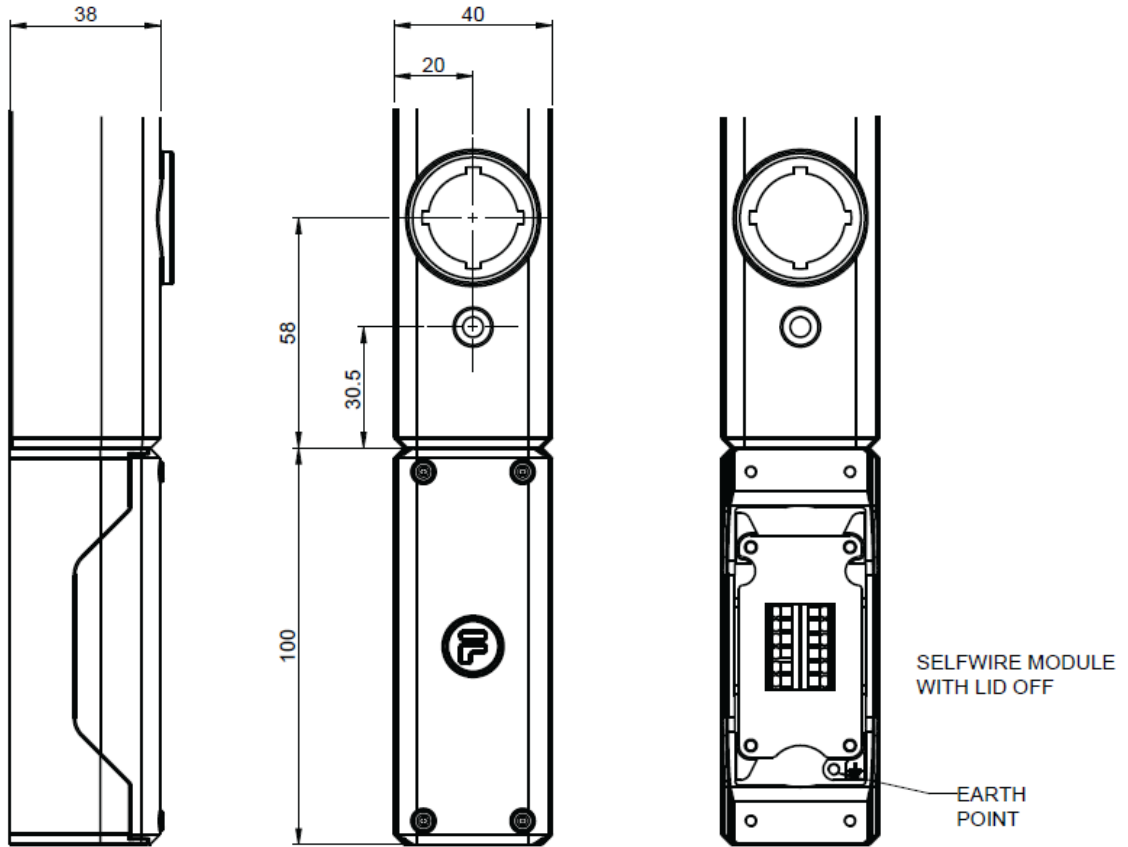



Safety & Control Trailing Cable

TC2, TC3, TC4, TC5, TC8, TC9



**Safety & Control Trailing Cable**

- Control Only or Safety & Control.
- 8/12/19 core, depending on requirement.
- 2m cable length for direct wiring to local junction / terminal box.

**Technical Specification**

Ingress Protection	IP65*
Ambient Temperature	-5°C to +40°C
Voltage	24V DC

\*IP protection is to the tGard stack that this module attaches to, when correctly fitted according to installation and maintenance instructions.

**Safety & Control Connector Part Number Options**

Part Number	Description
TC2	8 Core - Control Only
TC3	8 Core - Safety & Control
TC4	12 Core - Control Only
TC5	12 Core - Safety & Control
TC8	19 Core - Safety & Control
TC9	19 Core - Dual Safety & Control

**Trailing cable Core Pin Assignments**

Pins							
Part No.	TC2	TC3	TC4	TC5	TC8	TC9	Pin Assignment
Number of Core	8	8	12	12	19	19	
Cable Length	2m	2m	2m	2m	2m	2m	
# of Safety Circuits	0	2	0	2	2	4	
# of Control I/O	5	1	9	5	12	8	
	I/O 0	SC 1	+24v	+ 24v	SC 1	SC 1	
	+24v	+24v	I/O 0	SC 1	SC 2	SC 2	2
	Earth	Earth	0v	0 v	SC 1	SC 1	3
	I/O 1	SC 2	I/O 1	SC 2	SC 2	SC 2	4
	I/O 2	SC 2	I/O 2	SC 1	I/O 1	I/O 0	5
	I/O 3	SC 2	I/O 3	SC 2	0 v	0 v	6
	0 v	0v	I/O 4	I/O 0	I/O 1	I/O 1	7
	I/O 4	I/O 0	I/O 5	I/O 1	I/O 2	I/O 2	8
			I/O 6	I/O 2	I/O 3	I/O 3	9
			I/O 7	I/O 3	I/O 4	I/O 4	10
			I/O 8	I/O 4	I/O 5	I/O 5	11
			Earth	Earth	Earth	Earth	12
					I/O 6	I/O 6	13
					I/O 7	I/O 7	14
					I/O 8	SC 3	15
					I/O 9	SC 4	16
					I/O 10	SC 3	17
					I/O 11	SC 4	18
					+ 24v	+24v	19